

Uživatel'ský manuál

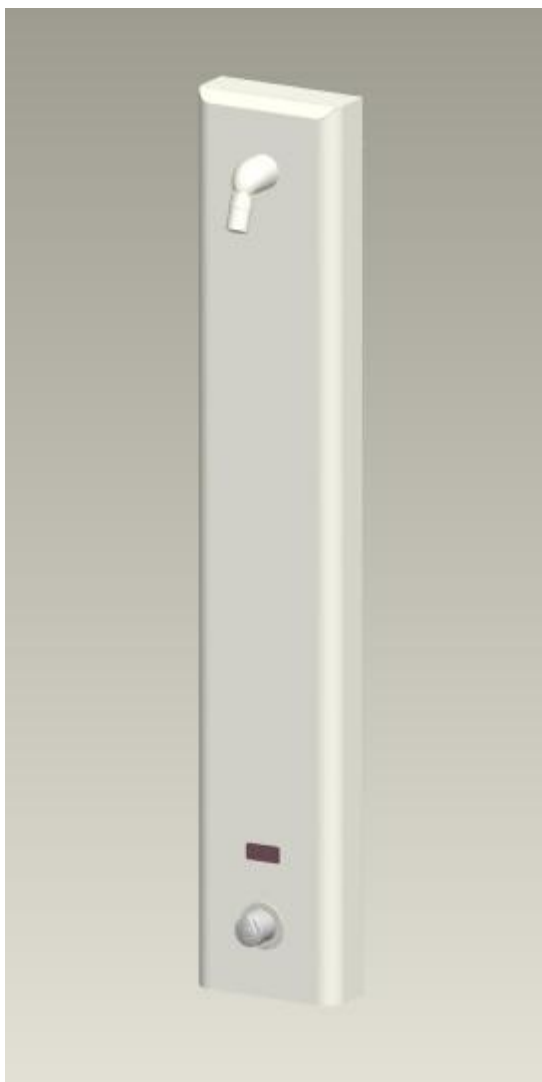

Sprcha s automatickým vypínáním

SABA Q1.2-REXT.1 BYP
SABA Q1.2-REXT.1 BYP/W
SABA Q3.2-REXT.1 BYP
SABA Q3.2-REXT.1 BYP/W

6V =

04.15.42.100
04.16.18.000
04.16.19.000
04.16.20.000

Var.1/17

VARIANTY

VAR. A

Štandard
l = 1250mm

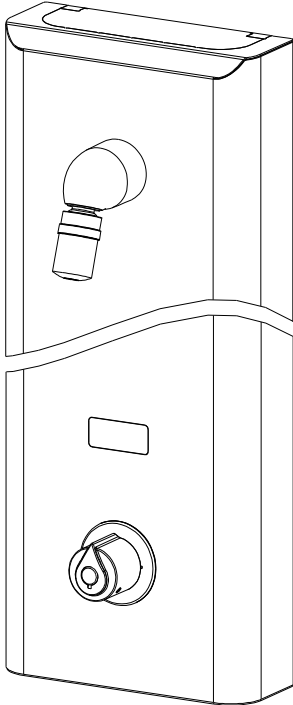

SABA Q1.2-REXT.1 BYP
04.15.42.100

Štandard - Biela
l = 1250mm

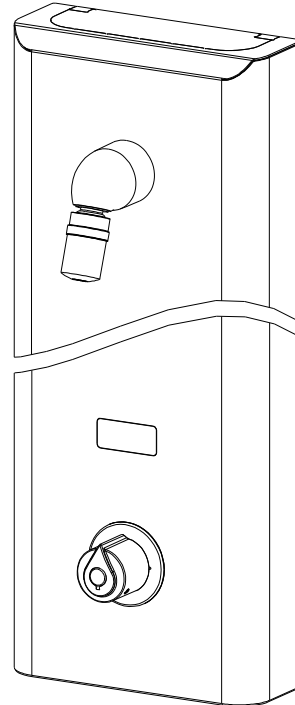

SABA Q1.2-REXT.1 BYP/W
04.16.18.000

VAR. B

Predĺžená
l = 1500mm

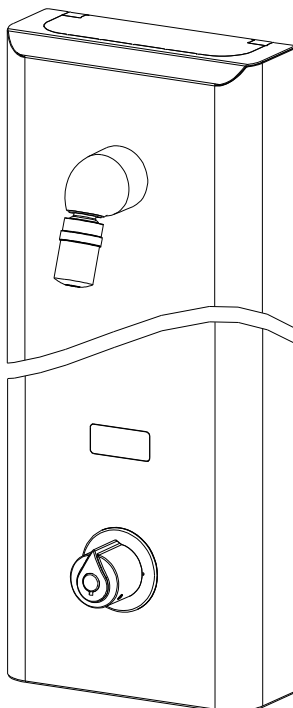

SABA Q3.2-REXT.1 BYP
04.16.19.000

Predĺžená - Biela
l = 1500mm

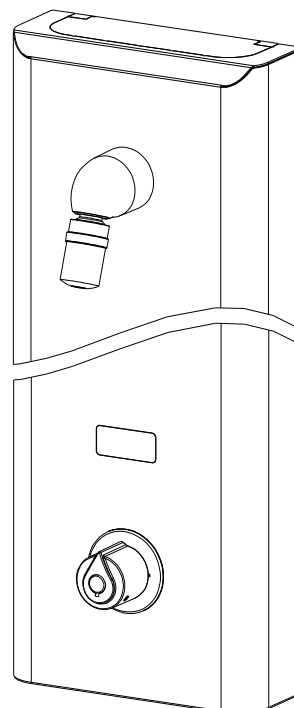

SABA Q3.2-REXT.1 BYP/W
04.16.20.000

04.15.42.100
04.16.18.000
04.16.19.000
04.16.20.000

1. Technické údaje

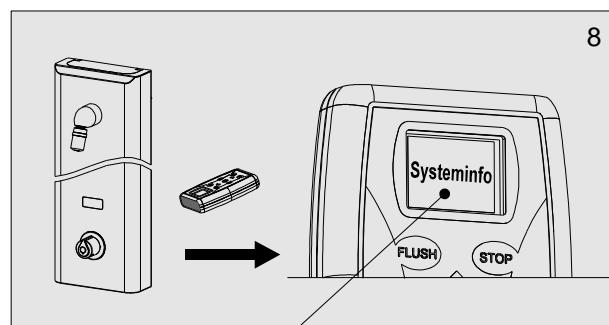
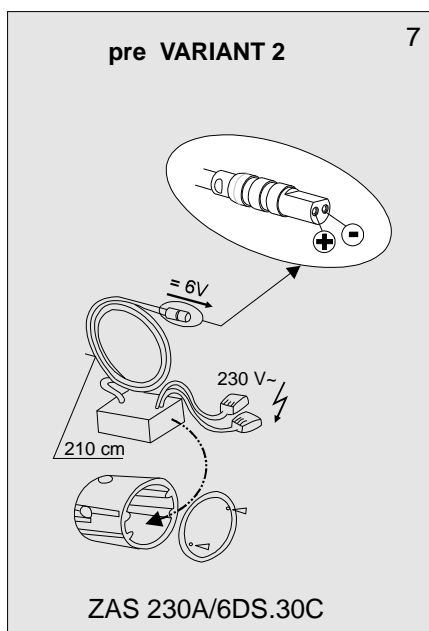
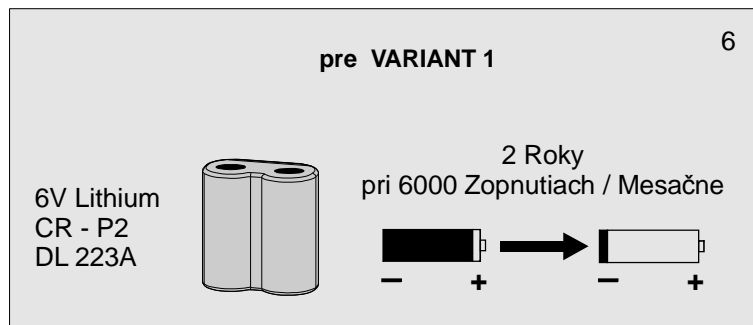
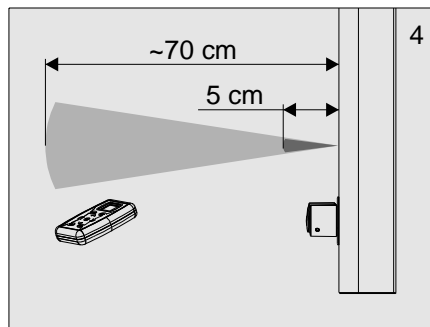
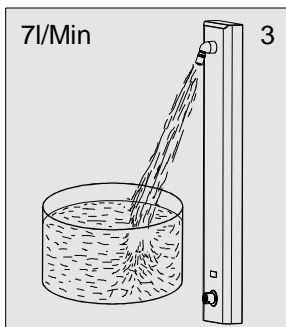
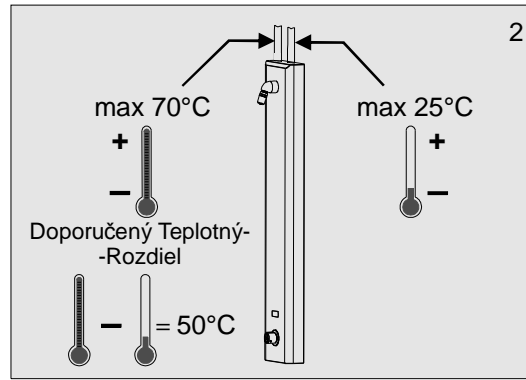
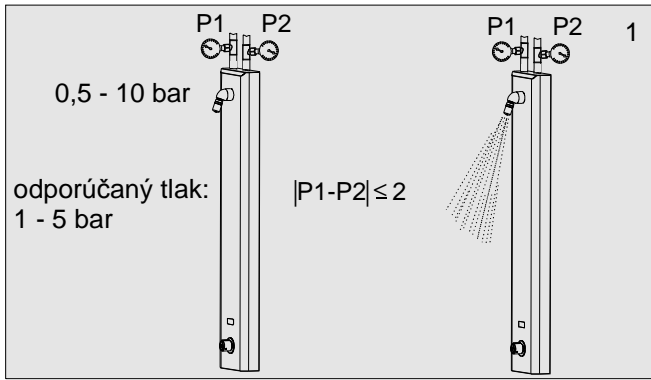

- Systeminfo:**
1. Sensor run time (doba prevádzky snímača)
 2. Valve cycles A:,B: (počet cyklov ventilu A:,B:)
 3. Code Number (kódové číslo)
 - Software ID (verzia programu)

2. Popis činnosti

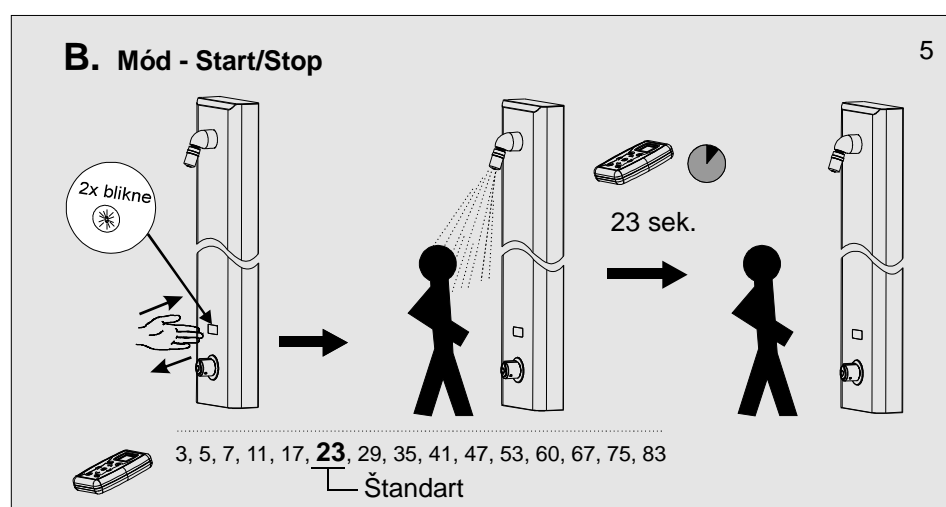
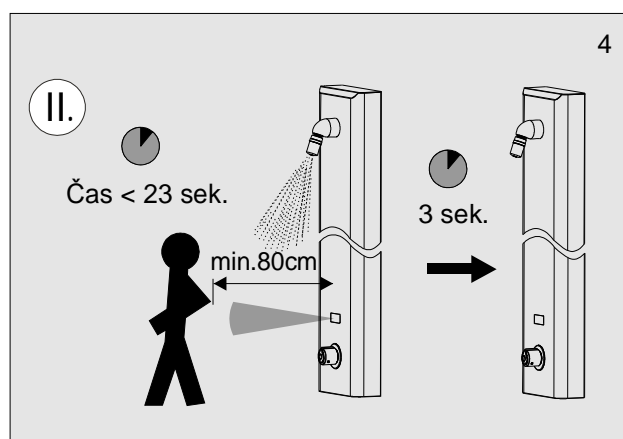
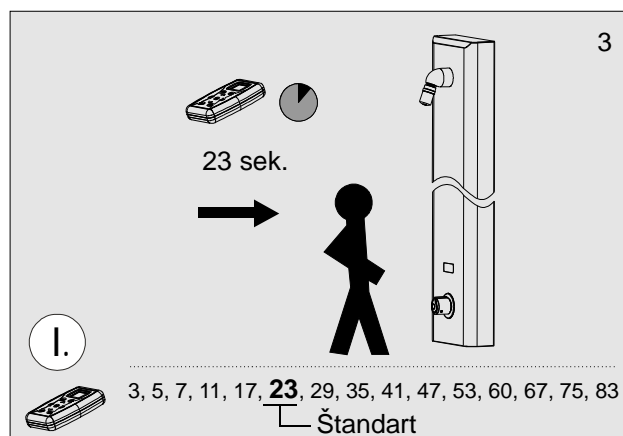
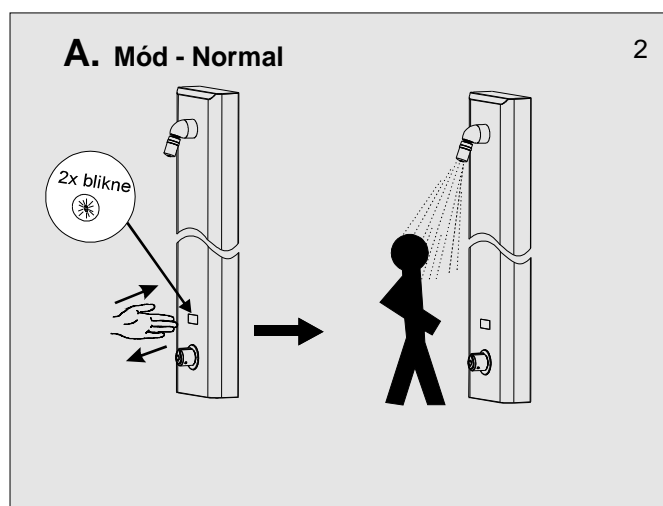
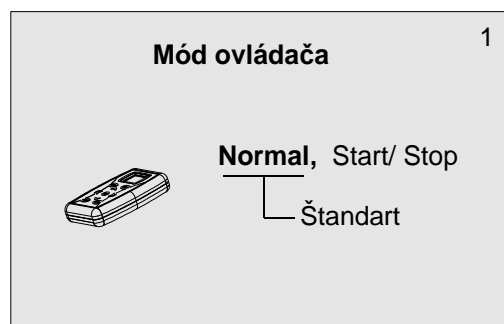

04.15.42.100
 04.16.18.000
 04.16.19.000
 04.16.20.000

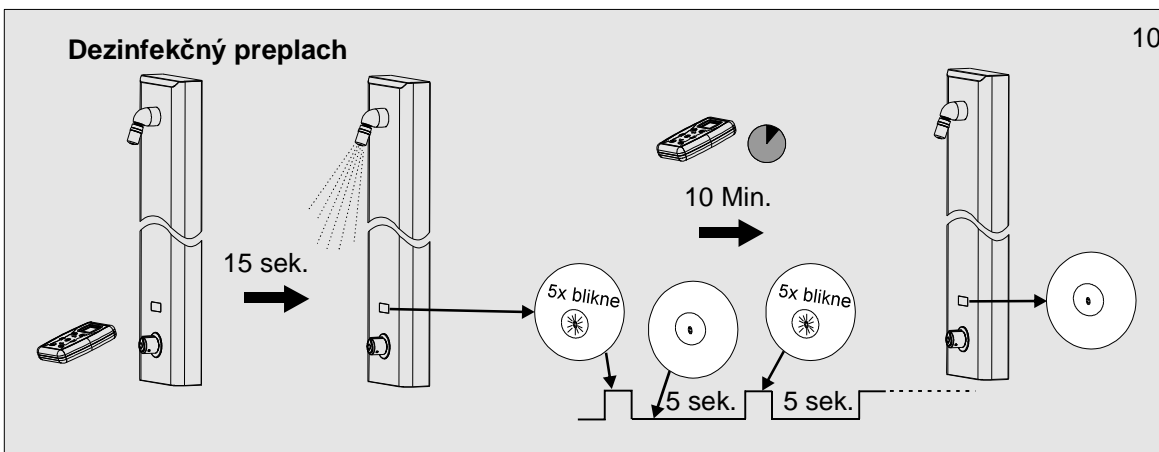
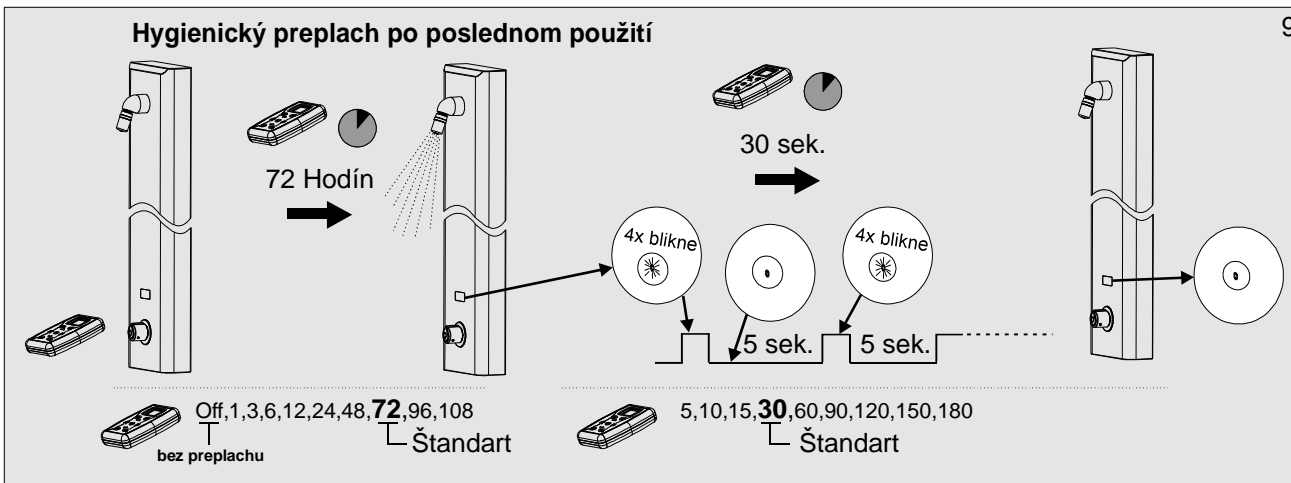
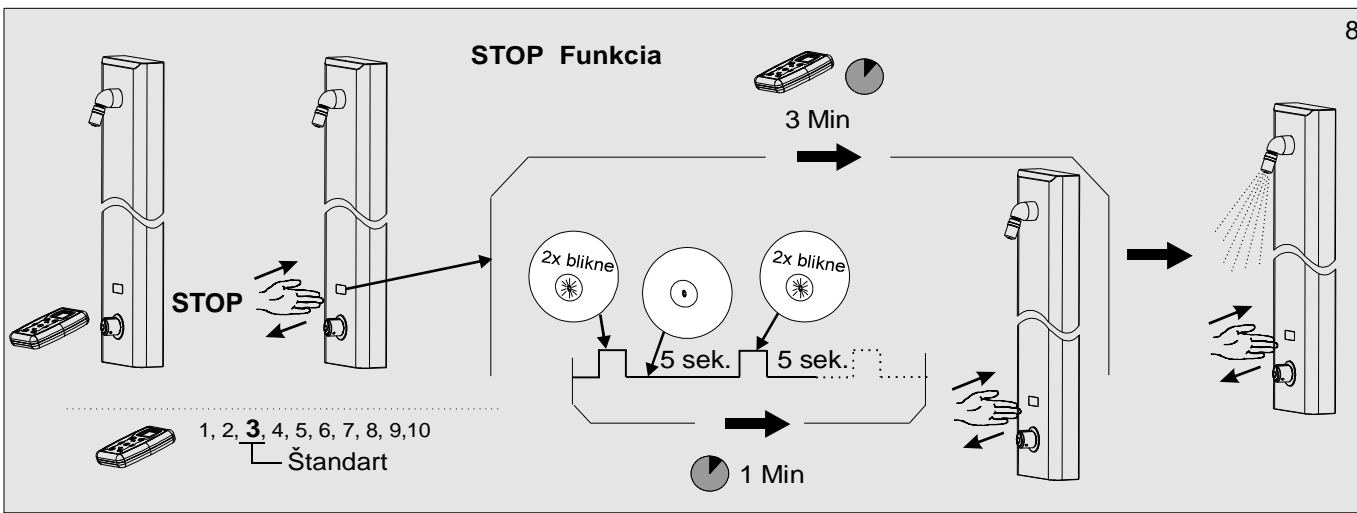
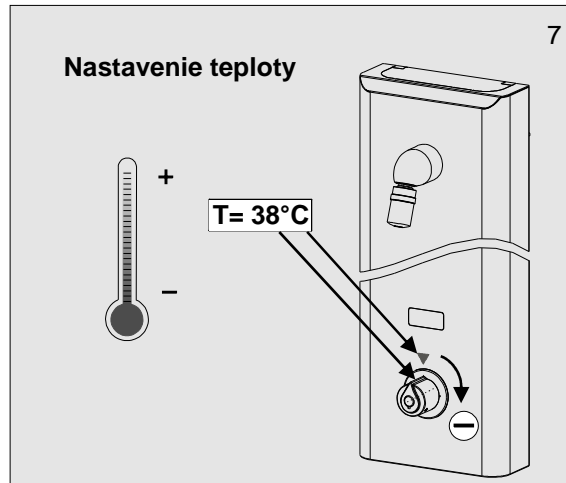
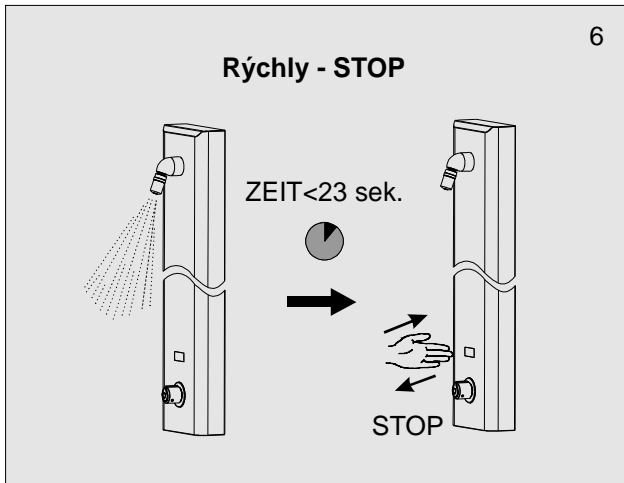

04.15.42.100
04.16.18.000
04.16.19.000
04.16.20.000

Externý Vstup pre Hygienický preplach

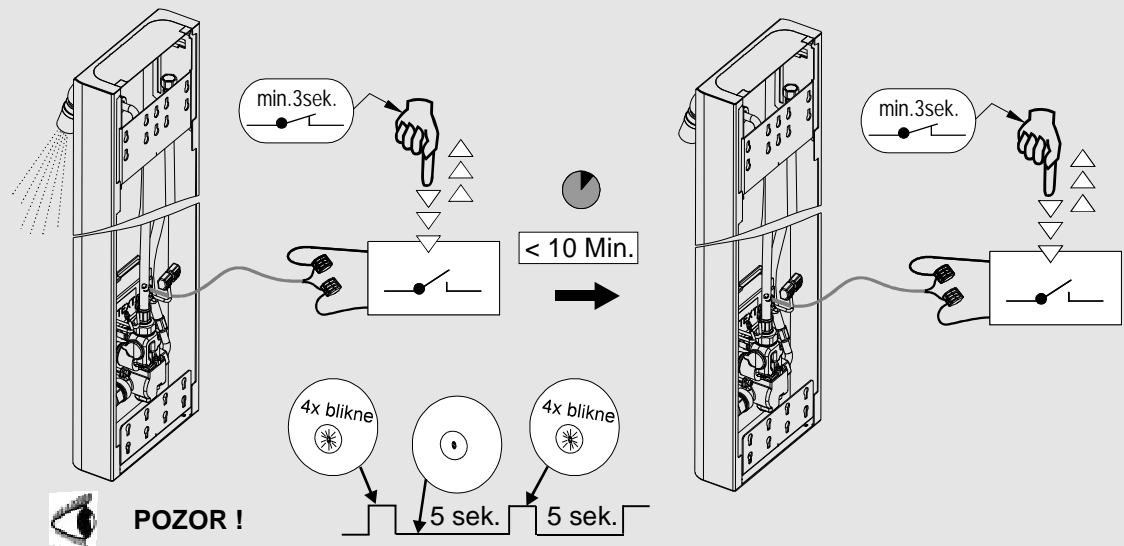
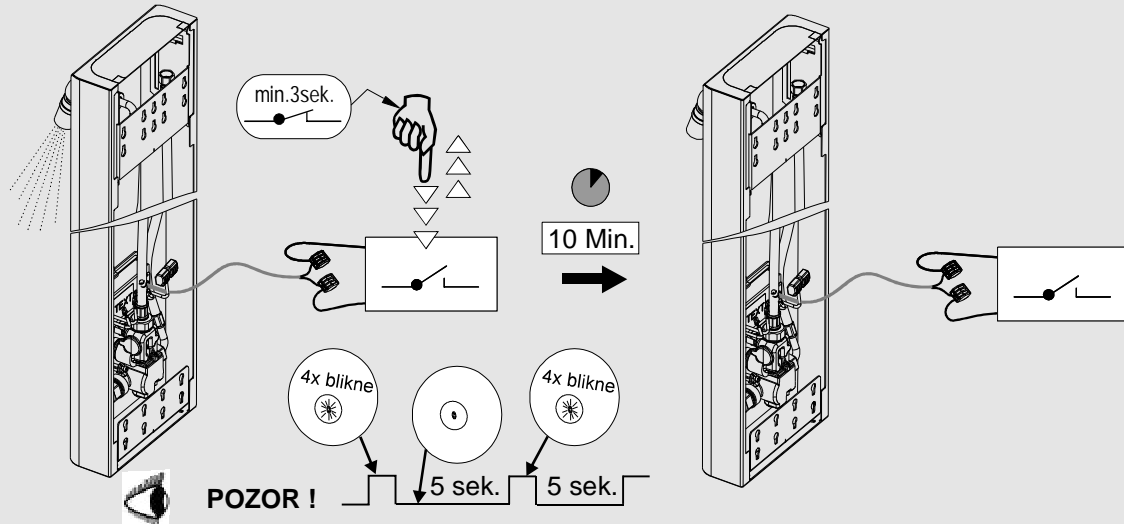

Externý Vstup pre Dezinfekčný preplach

12

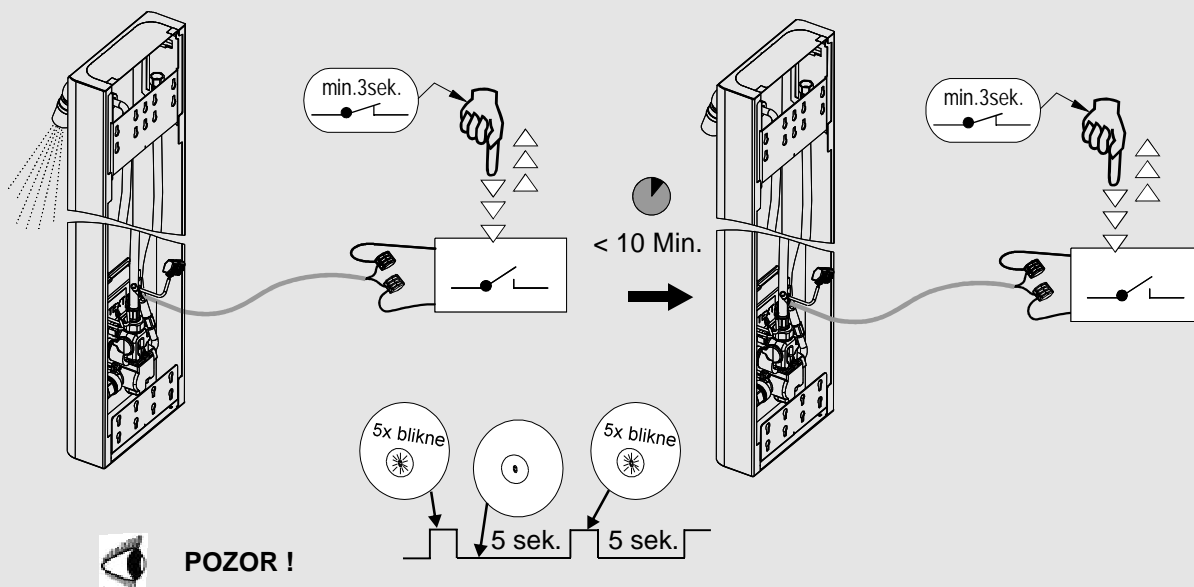
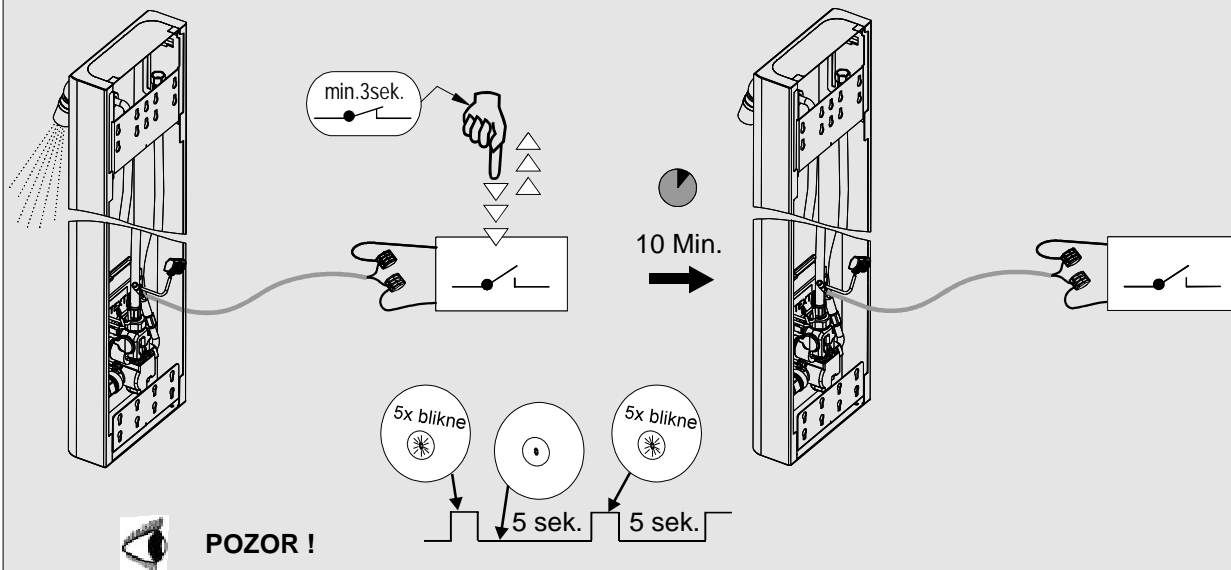

04.15.42.100
04.16.18.000
04.16.19.000
04.16.20.000

3.1 Základné rozmery - Prívod zo steny

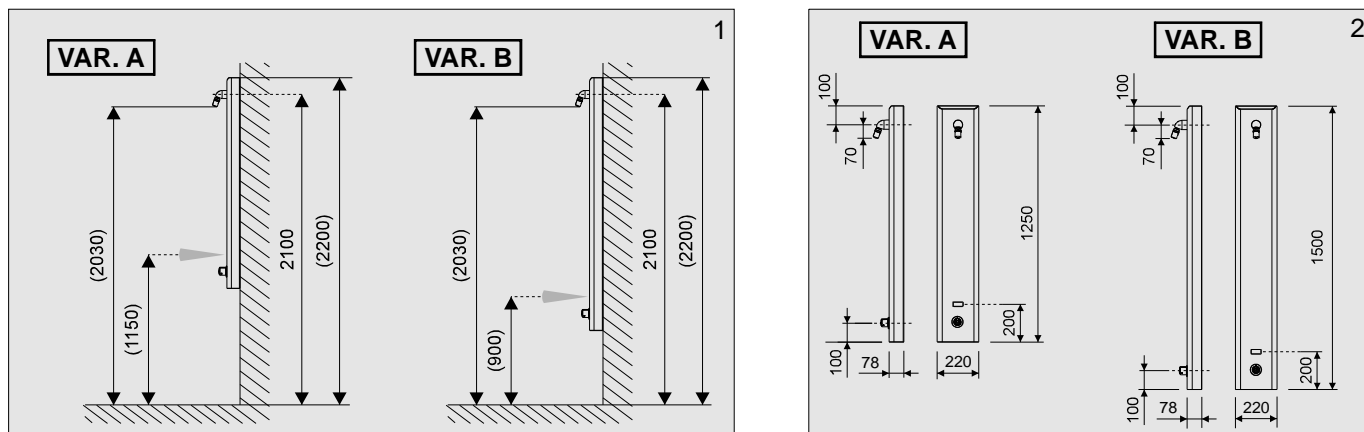

4.1 Stavebná pripravenosť - Prívod zo steny

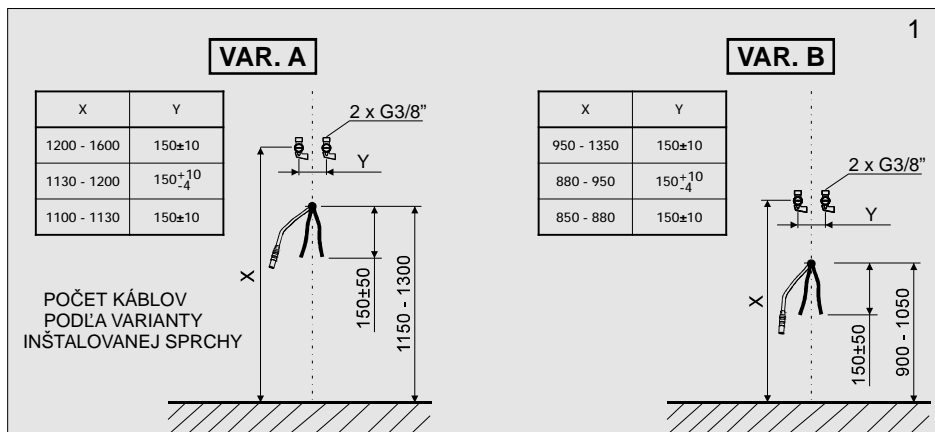

5.1 Inštalácia - Prívod zo steny

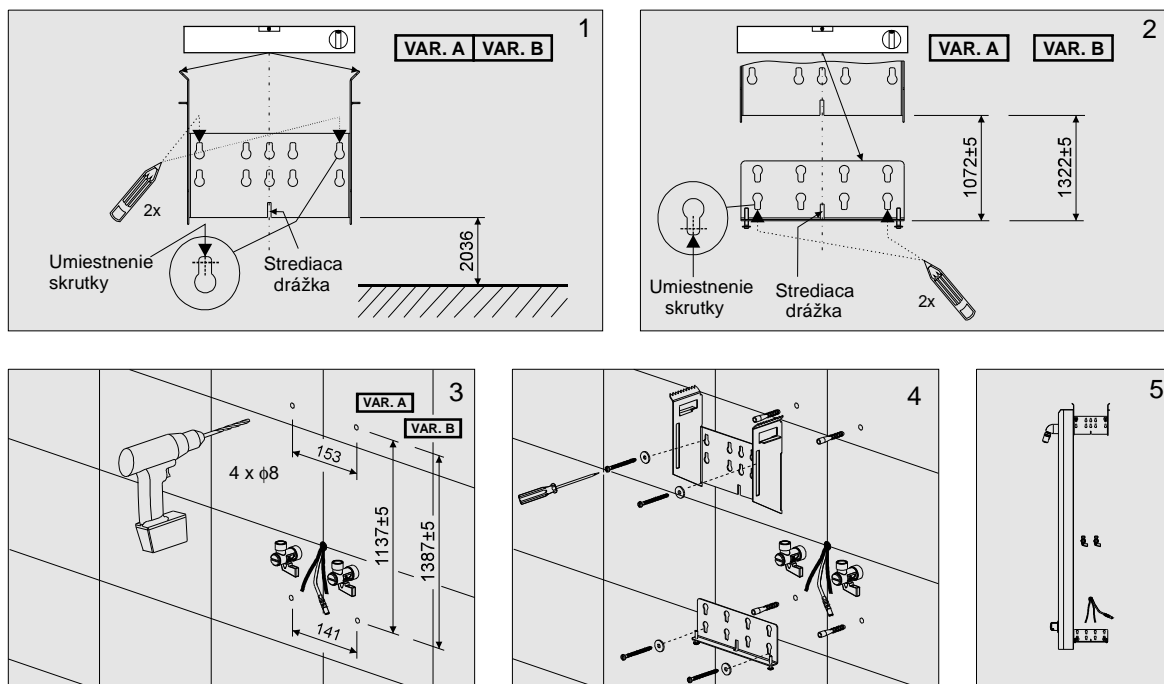

04.15.42.100
04.16.18.000
04.16.19.000
04.16.20.000

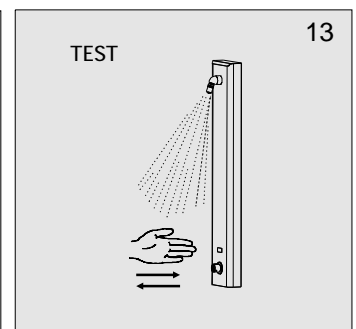
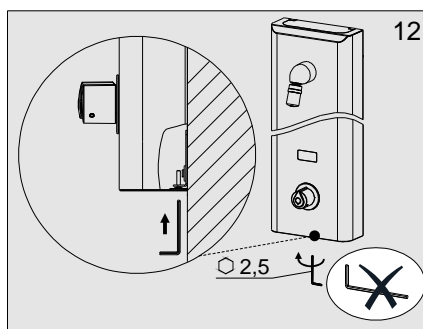
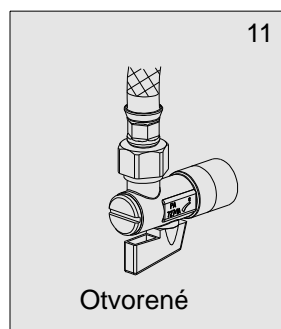
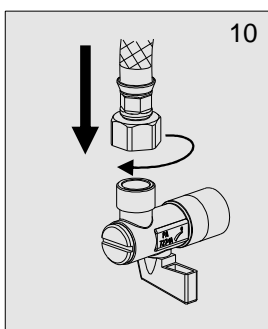
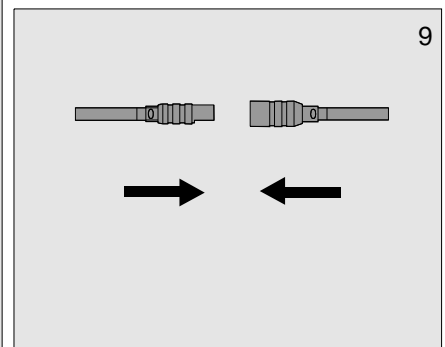
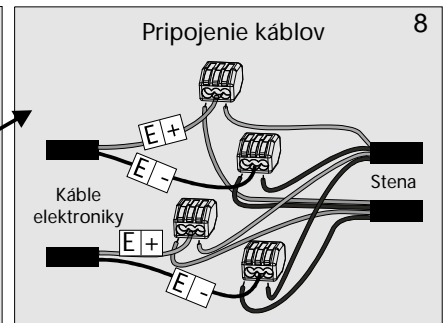
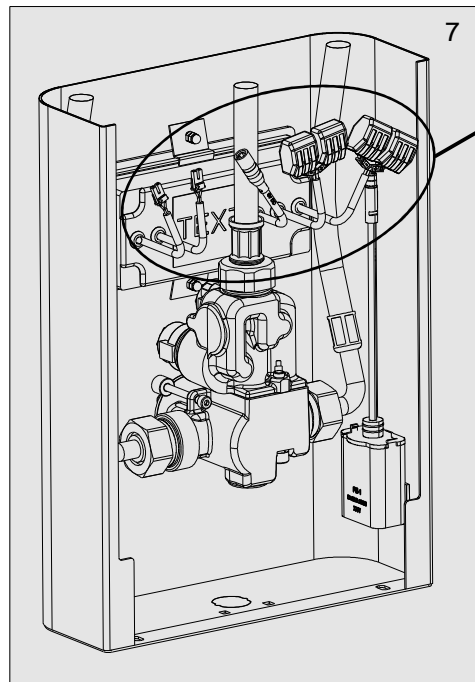
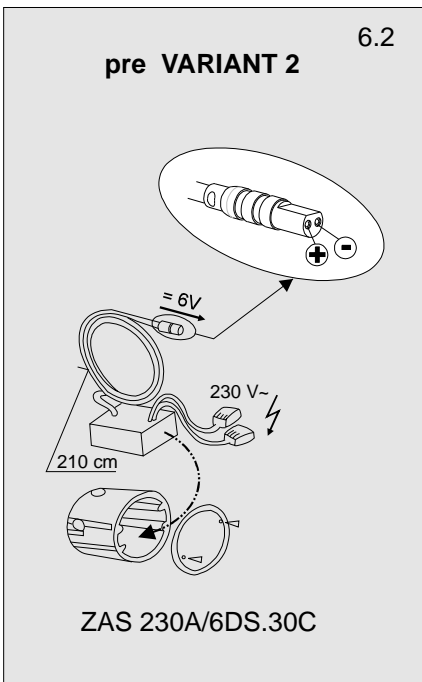
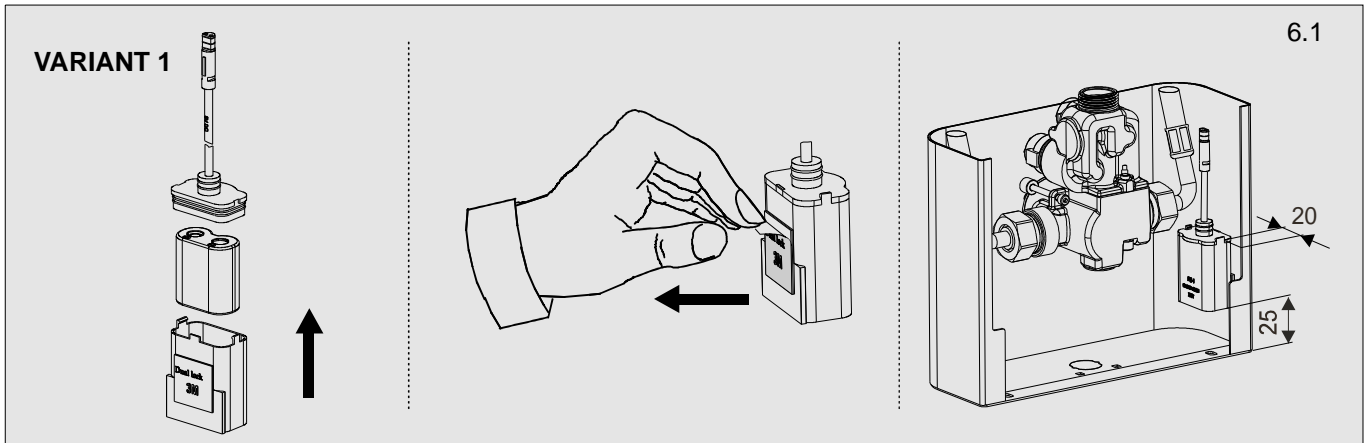

3.2 Základné rozmery - Prívod vody zo stropu

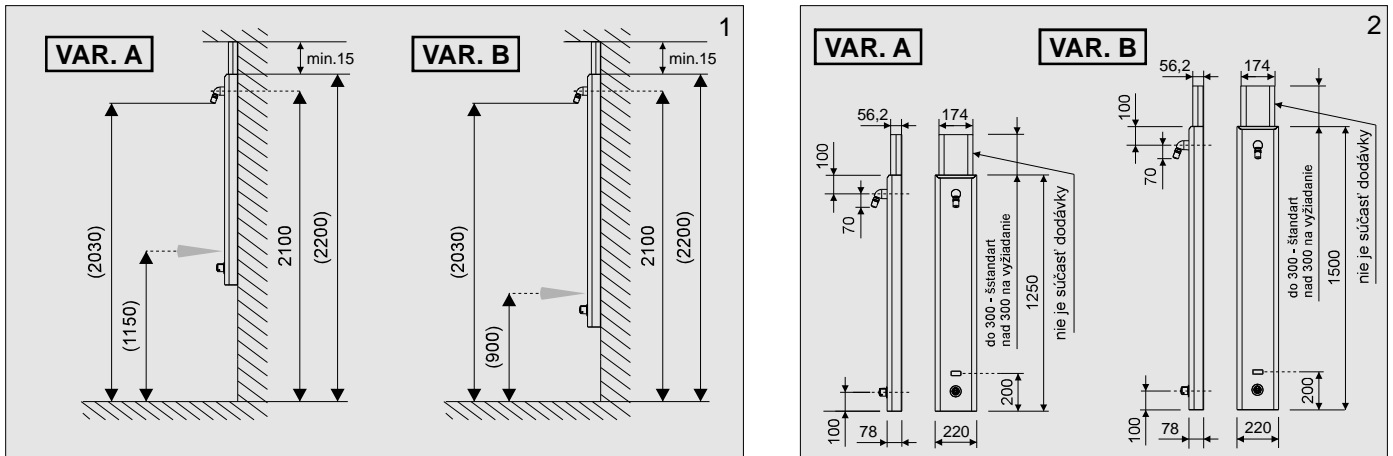

4.2 Stavebná pripravenosť - Prívod vody zo stropu

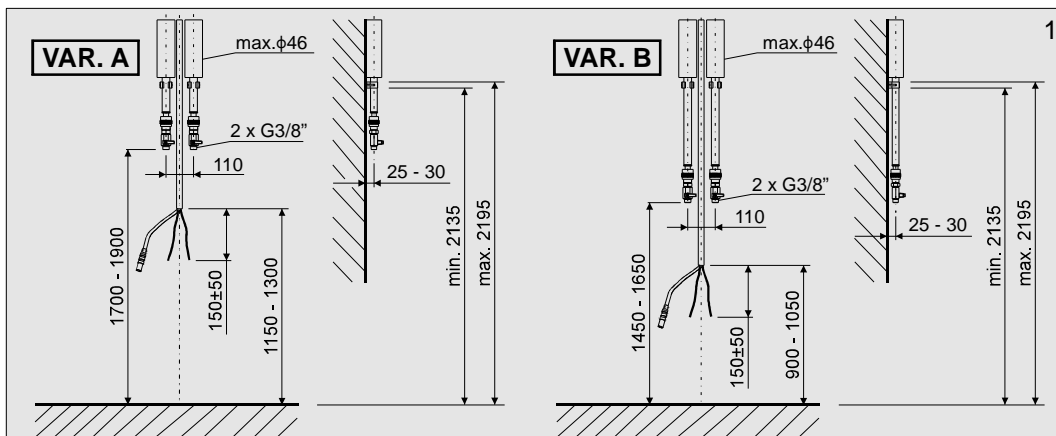

5.2 Inštalácia - Prívod vody zo stropu

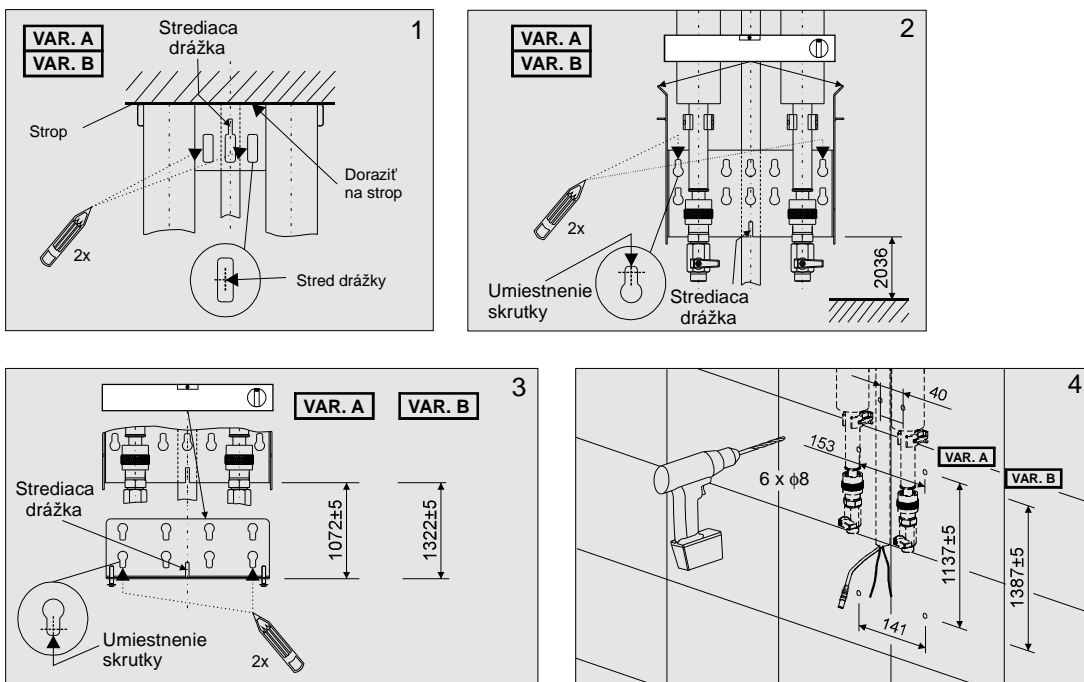

04.15.42.100
 04.16.18.000
 04.16.19.000
 04.16.20.000

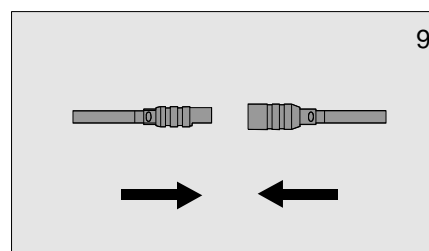
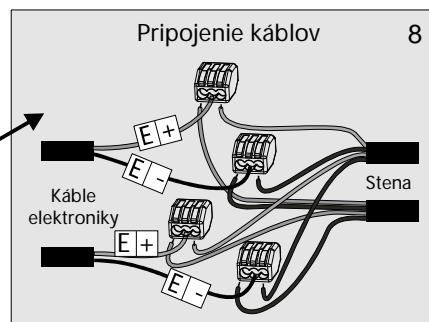
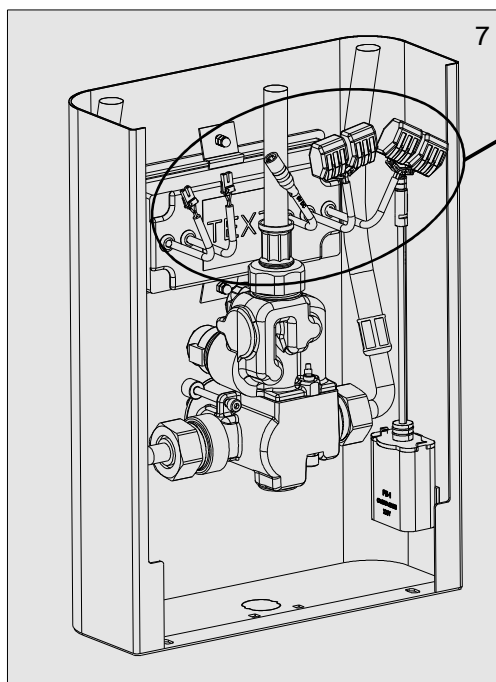
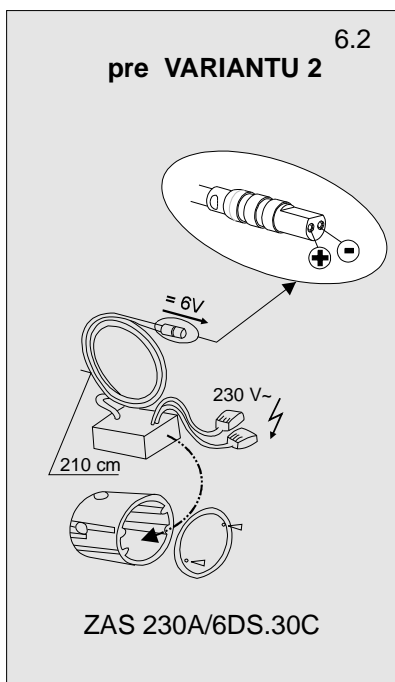
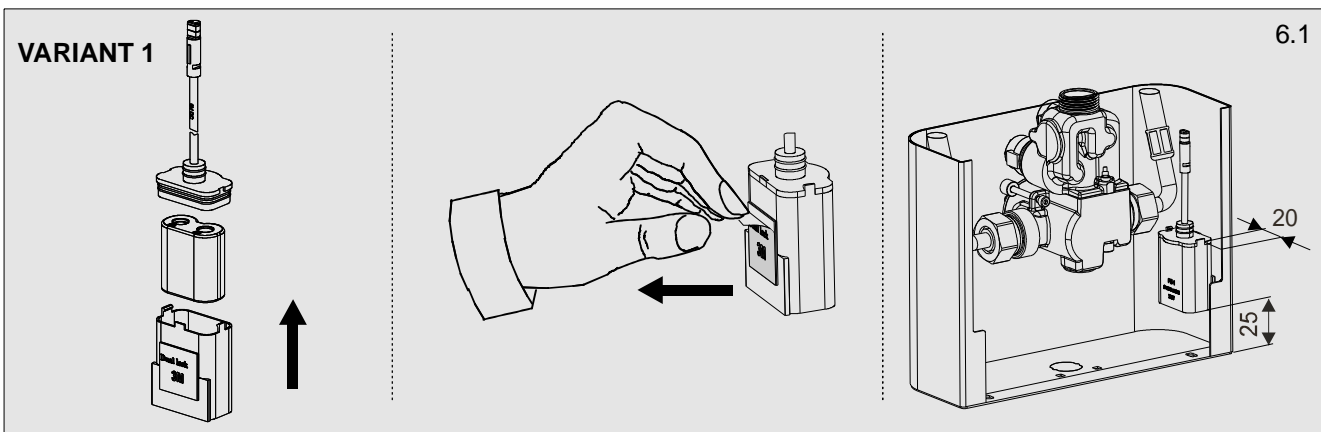
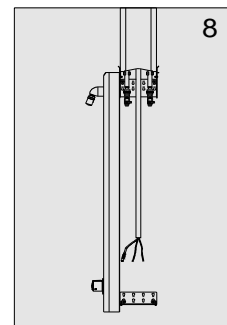
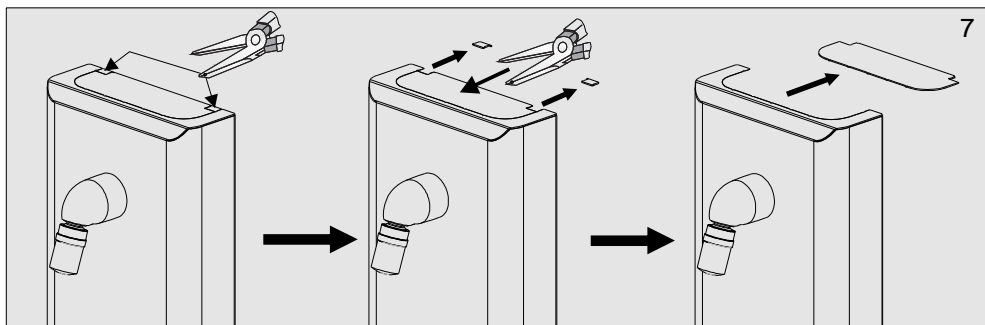
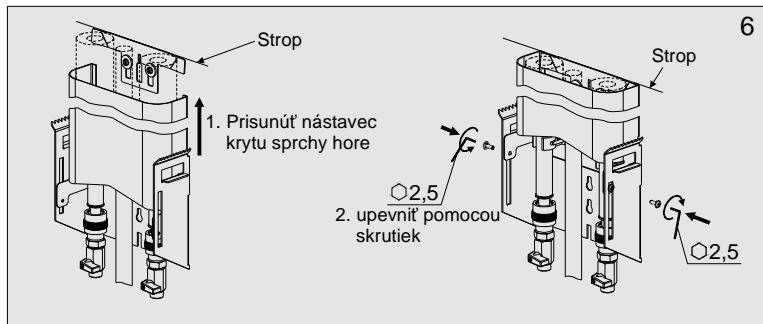
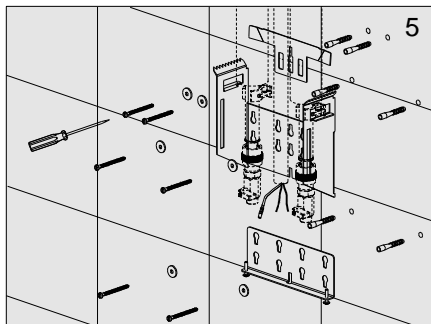

04.15.42.100
04.16.18.000
04.16.19.000
04.16.20.000

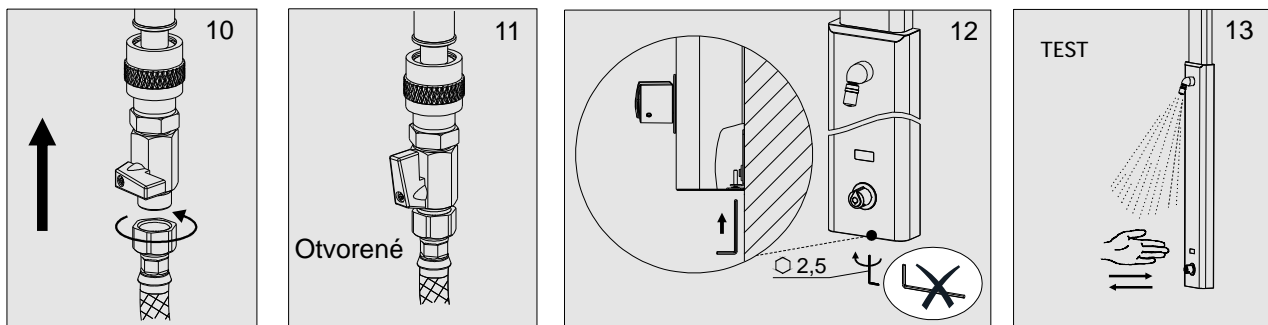

6. Čistenie filtrov

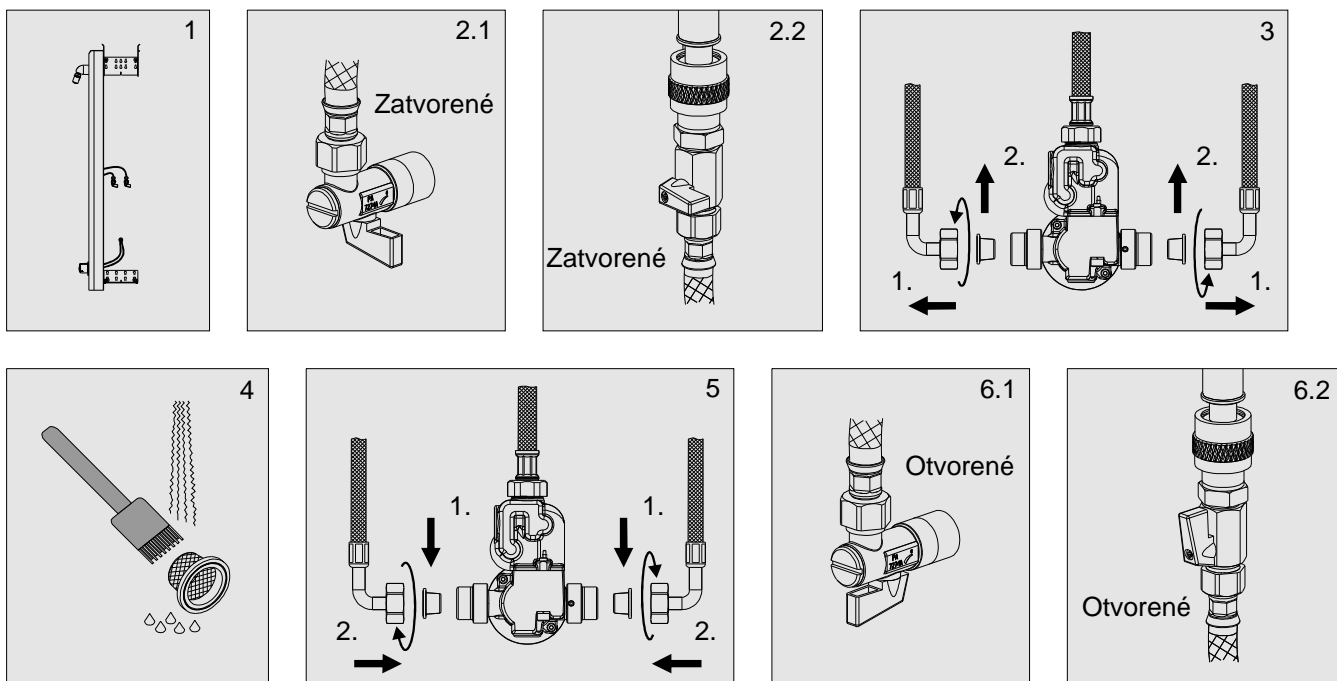

7. Výmena batérie

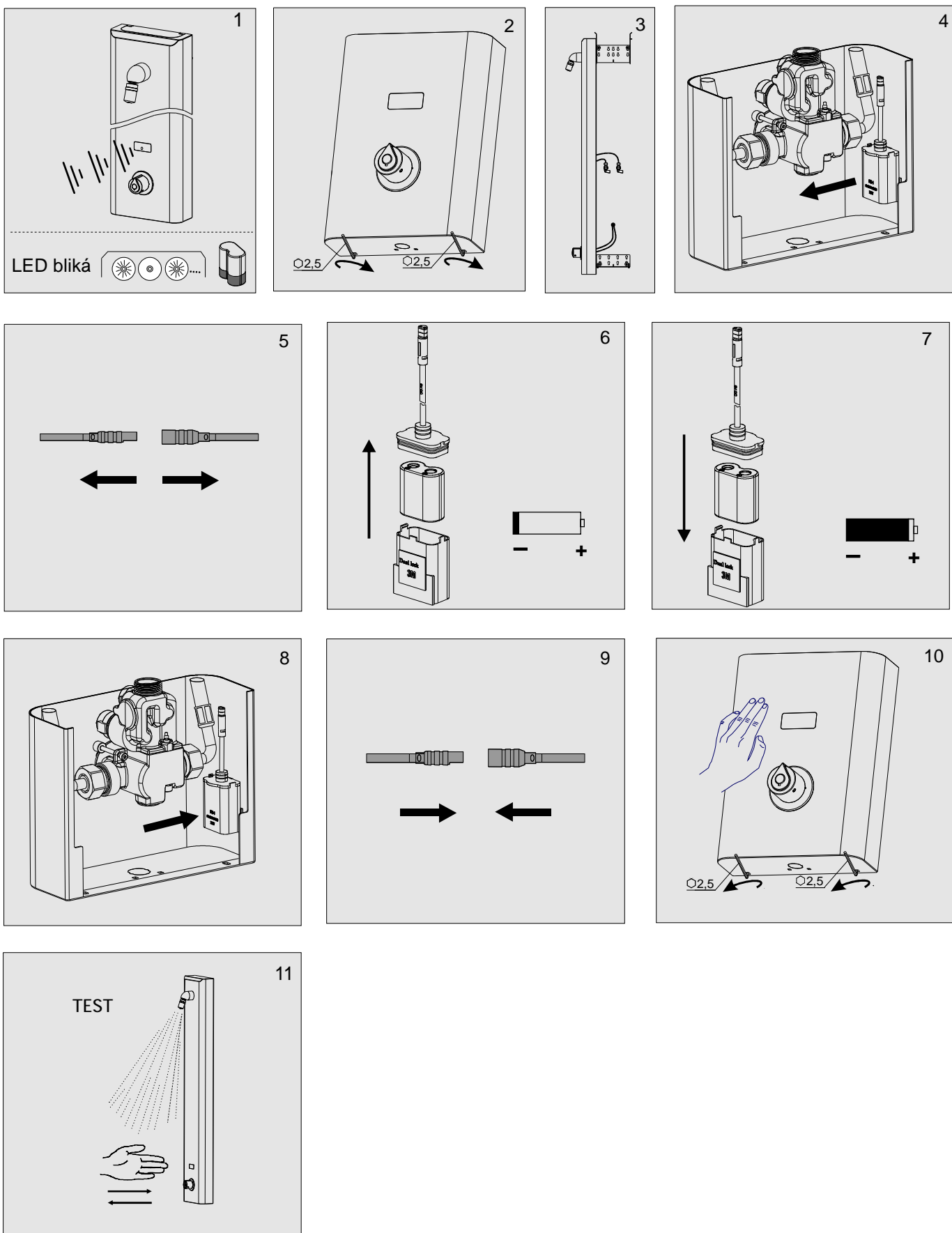

04.15.42.100
04.16.18.000
04.16.19.000
04.16.20.000

8. Riešenie problémov

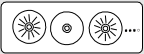
Problém	Príčina	Odstránenie závady
Netečie voda	• Zatvorený prívodný ventil	Otvoriť prívodný ventil
	• Vybitá batéria	Vymeniť batériu
	• Pokazený snímač	Zavolať servis
Bliká dióda 	• Vybitá batéria	Vymeniť batériu
Znížený prietok vody	• Upchatý filter	Vyčistiť filter
Stále tečie voda	• Pokazený elektromagnetický ventil	Zatvoriť prívodný ventil a volať servis

9. Dôležité upozornenia!

Varianta 1: Púzdro Batérie a 6V Batéria nie je súčasťou výrobku.

Varianta 2: bez Púzdra Batérie -ZAS 230A/6DS.30 nie je súčasťou výrobku.

Nepoužívajte mechanické čistiace prostriedky, ani prípravky s obsahom alkoholu, čpavku, kyseliny soľnej, kyseliny fosforečnej, kyseliny octovej a chlóru.

10. Náhradné diely

Výrobca: **SENZOR, s.r.o.**
 Park Angelinum 19, 040 01 Košice,
 Slovensko
 Tel.: +421 55-62 23013, -62 240 74
 Fax.: +421 55-62 229 02

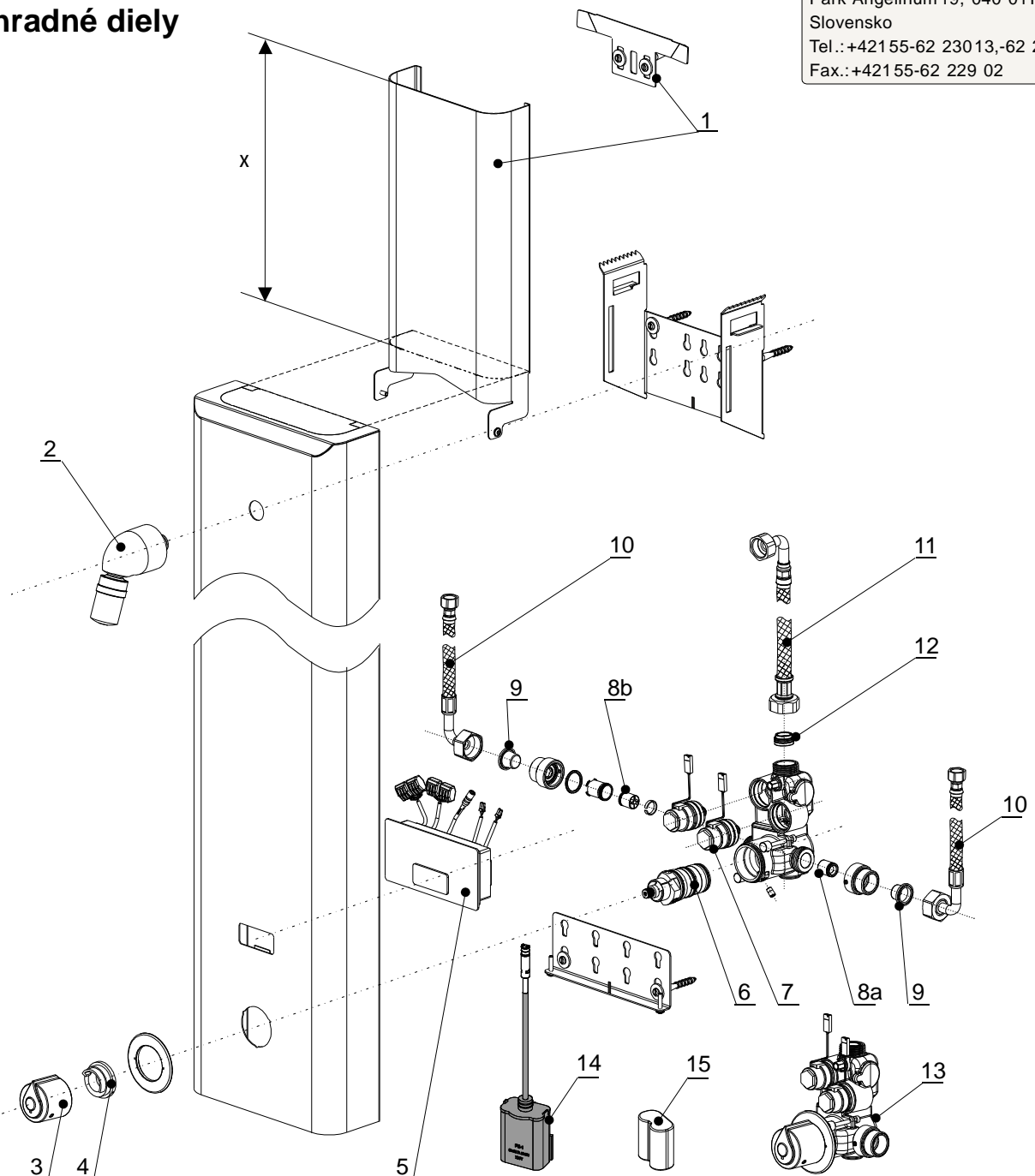

- | | | | |
|-----|------------------|--|-------------------------|
| 1. | CN: 04.15.67.000 | Nástavec krytu sprchy (x= 0-60mm) | nie je súčasťou výrobku |
| | CN: 04.15.74.000 | Nástavec krytu sprchy (x= 60-120mm) | nie je súčasťou výrobku |
| | CN: 04.15.75.000 | Nástavec krytu sprchy (x= 120-180mm) | nie je súčasťou výrobku |
| | CN: 04.15.76.000 | Nástavec krytu sprchy (x= 180-240mm) | nie je súčasťou výrobku |
| | CN: 04.15.68.000 | Nástavec krytu sprchy (x= 240-300mm) | nie je súčasťou výrobku |
| 2. | PLU:1/2139 | Sprchová hlavica 7l / min | |
| 3. | CN: 11.01.32.000 | Gombík | |
| 4. | PLU 1/7992 | Doraz gombíka | |
| 5. | CN: 04.16.14.000 | Elektronika | |
| 6. | PLU 1/14804 | Termostatická kartuša | |
| 7. | CN: 02.41.05.000 | Magnetický ventil | |
| 8a. | PLU 1/1737 | Spätný ventil | |
| 8b. | PLU 1/15005 | Spätný ventil | |
| 9. | PLU 1/137 | Filter | |
| 10. | PLU 1/14815 | Hadica | |
| 11. | PLU 1/14814 | Hadica VAR A: SABA Q1 | |
| | PLU 1/14953 | Hadica VAR B: SABA Q3 | |
| 12. | CN: 04.15.80.000 | Obmedzovač prietoku 12l / min. | nie je súčasťou výrobku |
| 13. | CN: 04.15.20.000 | Termostatický blok s Magnetickými ventilmi | |
| 14. | CN: 06.21.52.000 | Púzdro batérie | nie je súčasťou výrobku |
| 15. | PLU 1/1721 | 6V Batéria | nie je súčasťou výrobku |

04.15.42.100
 04.16.18.000
 04.16.19.000
 04.16.20.000